



晶采光電科技股份有限公司
AMPIRE CO., LTD.

SPECIFICATIONS FOR LCD MODULE

CUSTOMER	
CUSTOMER PART NO.	
AMPIRE PART NO.	AM-19201080D1TZQW-T02H
APPROVED BY	
DATE	

- Preliminary Specification
 Formal Specification

AMPIRE CO., LTD.

**4F., No.116, Sec. 1, Sintai 5th Rd., Sijhih City, Taipei County 221,
Taiwan (R.O.C.)台北縣汐止市新台五路一段 116 號 4 樓(東方科學園區 A 棟)
TEL:886-2-26967269 , FAX:886-2-26967196 or 26967270**

APPROVED BY	CHECKED BY	ORGANIZED BY
Kokai	Mark	Lawlite

This Specification is subject to change without notice.

RECORD OF REVISION

Revision Date	Page	Contents	Editor
2021/12/24	--	New Release	Lawlite

1.0 General Descriptions

1.1 Introduction

The LCM is a color active matrix TFT LCD module using amorphous silicon TFT's (Thin Film Transistors) as an active switching devices. This module has a 15.6 inch diagonally measured active area with FHD resolutions (1920 horizontal by 1080 vertical pixel array). Each pixel is divided into RED, GREEN, BLUE dots which are arranged in vertical Stripe and this module can display 16M colors(6bit+FRC). The TFT-LCD panel used for this module is a low reflection and higher color type.

1.2 Features

- 3.3 V Logic Power
- LVDS (2ch) Interface for 1920 RGB x 1080 resolution
- 16M Colors(6bit+FRC)
- On board LED Driving circuit
- Green Product (RoHS)

1.3 Product Summary

Items	Specifications	Unit
Screen Diagonal	15.6	Inch
Active Area	344.16 (H) x193.59 (V)	mm
Pixel Format	1920 (H) x RGB x 1080 (V)	-
Pixel Pitch	0.17925 (H) X 0.17925 (V)	mm
Pixel Arrangement	R.G.B. Vertical Stripe	-
Display Mode	Normally Black	-
White Luminance	380 (Typ)	cd /m2
Contrast Ratio	800 : 1 (Typ)	-
Input Voltage	3.3	V
Support Color	16M(6Bit+FRC)	-

2.0 Absolute Maximum Ratings

ITEM	SYMBOL	VALUES		UNIT	REMARK
		MIN	MAX		
Logic Signal Input Level	V _{in}	-0.3	4.0	V	
Power Supply Voltage	V _{cc}	-0.3	3.6	V	
Operation Temperature	T _{op}	-20	70	°C	
Storage Temperature	T _{st}	-30	80	°C	

Note (1) T_a =25±2°C

3.0 ELECTRICAL SPECIFICATIONS

3.1 LCD ELECTRONICS SPECIFICATION

Parameter	Symbol	Value			Unit	Note
		Min	Typ.	Max.		
Power Supply Voltage	Vcc	3.15	3.3	3.6	V	-
Ripple Voltage	VRP	-	-	150	mV	-
Rush Current	IRUSH	-	-	3	A	(2)
Power Supply Current	White	-	1.22	1.5	A	(3)a
	Black	-	0.51	0.7	A	(3)b
	Vertical Stripe	-	0.82	1	A	(3)c
Power Consumption	PLCD	-	4	5	Watt	(4)
LVDS differential input voltage	Vid	200		600	mV	(5)
LVDS common input voltage	Vic	1.0	1.2	1.4	V	(6)
LVDS terminating resistor	Rt		100		ohm	

Note(1) The ambient temperature is $T_a = 25 \pm 2^\circ\text{C}$

Note(2) Measurement Conditions:

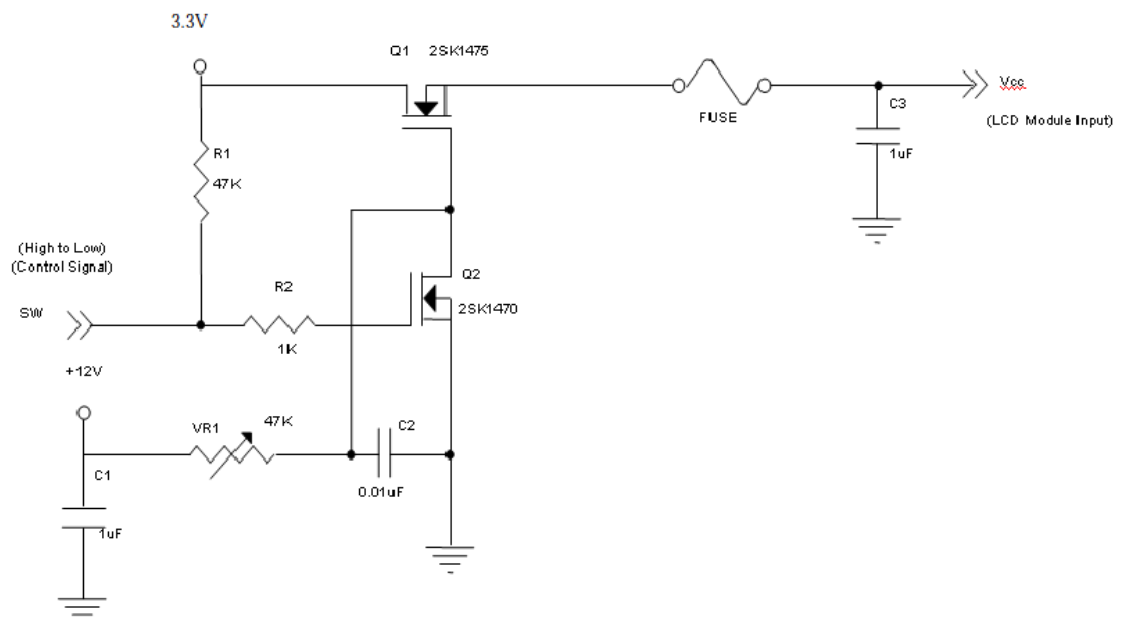

Vcc rising time is 470μs

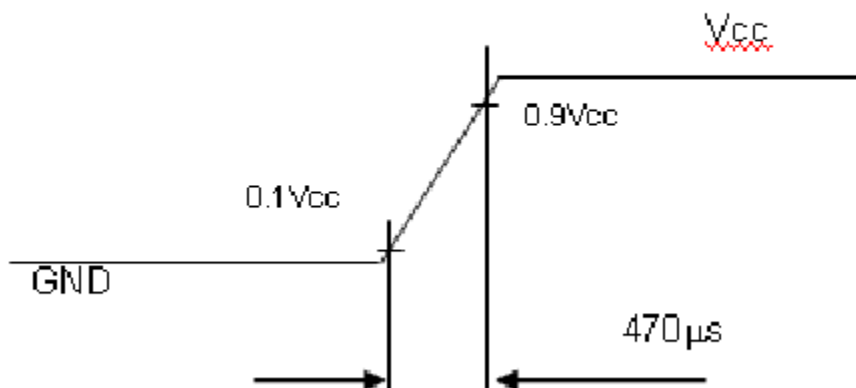

Note(3) The specified power supply current is under the conditions at $V_{CC}=3$ 3V, $T_a=25\pm 2^{\circ}\text{C}$, $F_r=60\text{Hz}$, whereas a power dissipation check pattern below is displayed.

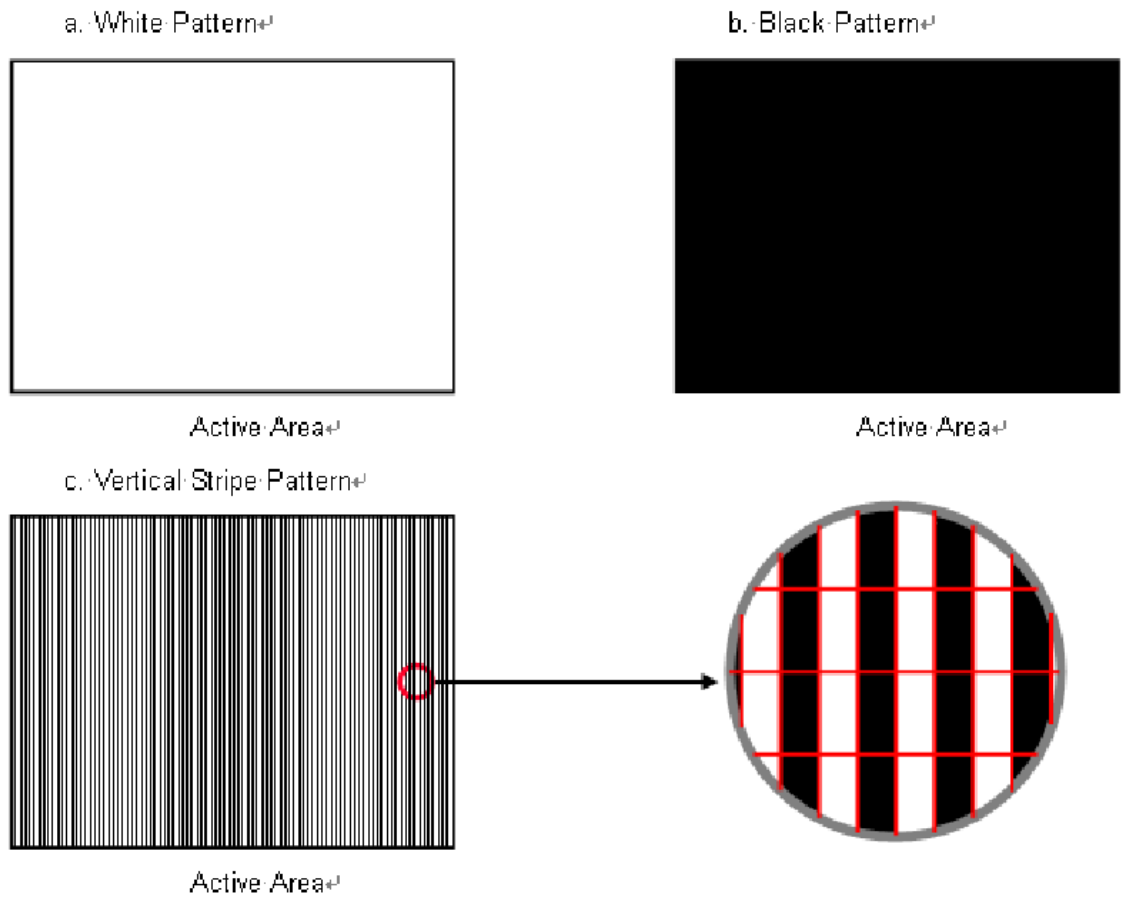

Note(4) The power consumption is specified at the pattern with the maximum current.

Note(5) VID waveform condition

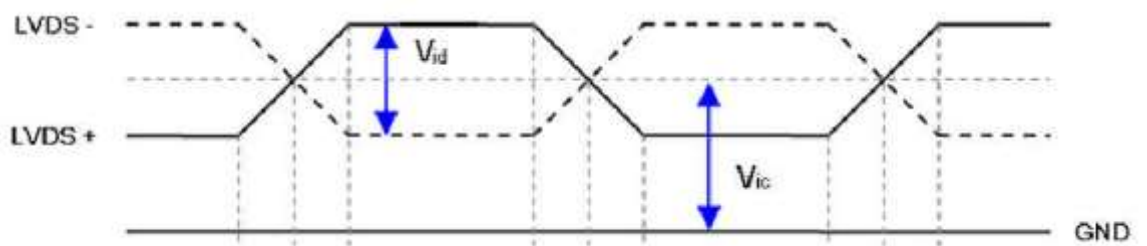

4. Interface Timings

4.1 DISPLAY TIMING SPECIFICATIONS

The input signal timing specifications are shown as the following table and timing diagram.

Signal	Item	Symbol	Min.	Typ.	Max.	Unit	Note
LVDS Clock	Frequency	F _c	60	70.93	75	MHz	-
	Period	T _c		14.1		ns	
	Input cycle to cycle jitter	T _{rd}	-0.02*T _c		0.02*T _c	ns	(3)
	Input clock to data skew	TLVCCS	-0.02*T _c		0.02*T _c	ns	(4)
	Spread spectrum modulation range	F _{clk_in_mod}	FC*98%		FC*102%	MHz	(5)
	Spread spectrum modulation frequency	F _{SSM}			200	KHz	
Vertical Display Term	Frame Rate	Fr	50	60	60	Hz	T _v =T _{v_d} +T _{v_b}
	Total	T _v	1090	1110	1130	Th	-
	Active Display	T _{v_d}	1080	1080	1080	Th	-
	Blank	T _{v_b}	T _v -T _{v_d}	30	T _v -T _{v_d}	Th	-
Horizontal Display Term	Total	T _h	1050	1065	1075	T _c	T _h =T _{h_d} +T _{h_b}
	Active Display	T _{h_d}	960	960	960	T _c	-
	Blank	T _{h_b}	T _h -T _{h_d}	105	T _h -T _{h_d}	T _c	-

Note(1) Because this module is operated by DE only mode, Hsync and Vsync input signals are ignored.

Note(2) The T_v (T_{v_d}+T_{v_b}) must be integer, otherwise this module would operate abnormally.

INPUT SIGNAL TIMING DIAGRAM

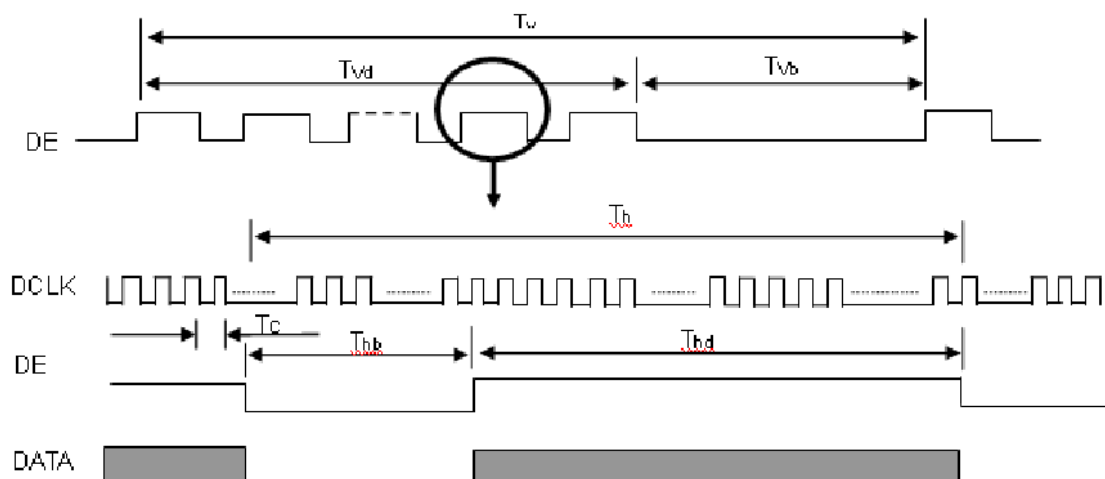

Note(3) The input clock cycle-to-cycle jitter is defined as below figures. $Trcl = |T_1 - T_2|$

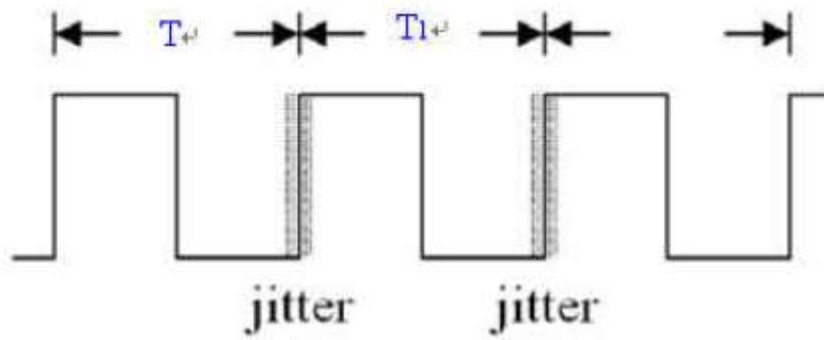

Note(4) Input Clock to data skew is defined as below figures.

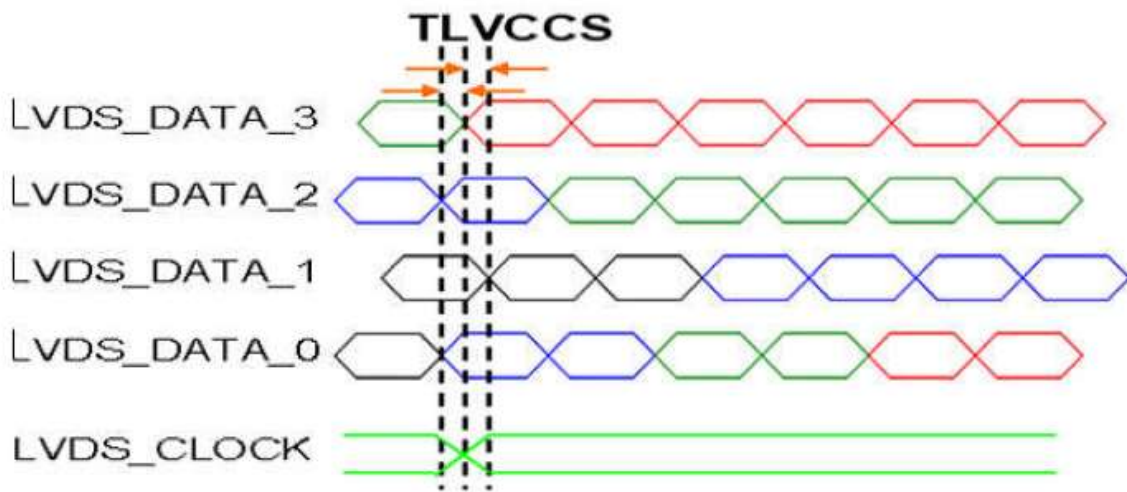

Note(5) The SSCG (Spread spectrum clock generator) is defined as below figures.

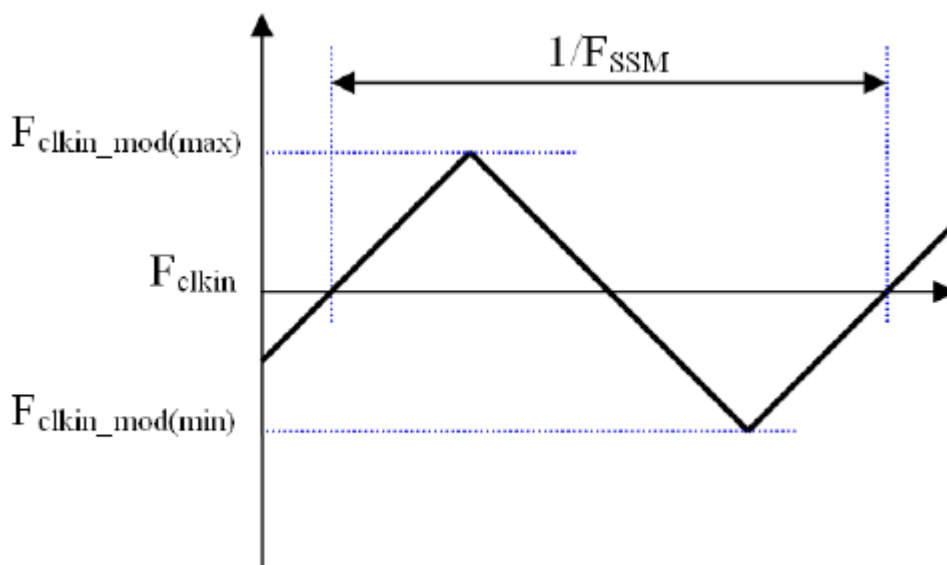

4.2 POWER ON/OFF SEQUENCE

The power swquence specifications are shown as the following table and diagram.

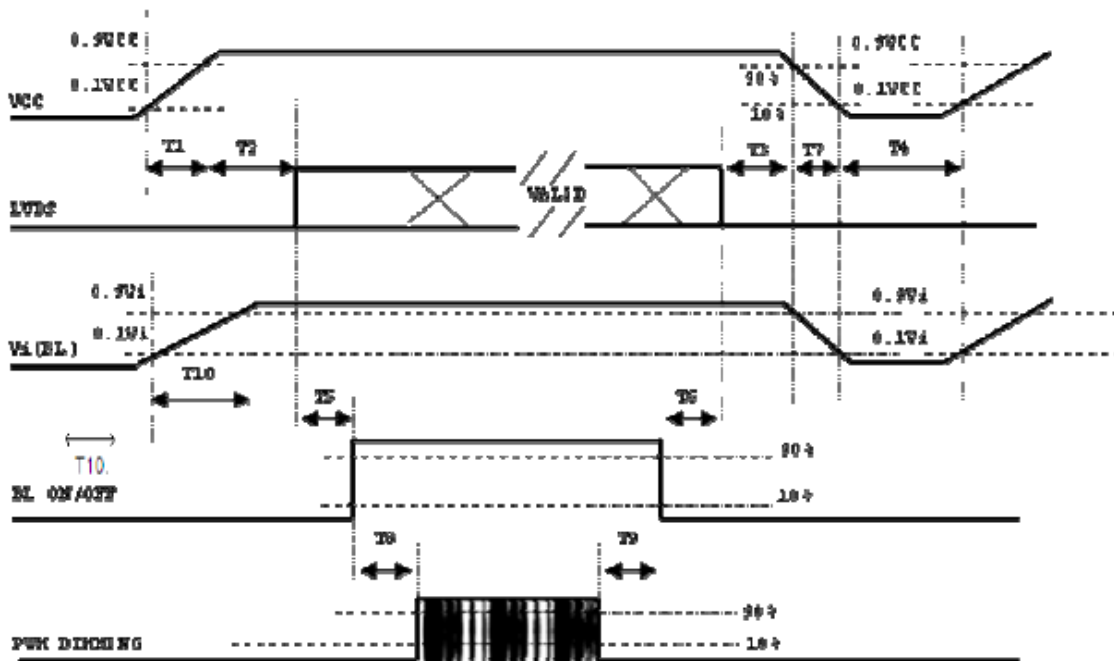

Timing Specifications:

Parameter	Value			Units
	Min	Typ	Max	
T1	0.5	-	10	ms
T2	0	-	50	ms
T3	0	-	50	ms
T4	500	-	-	ms
T5	450	-	-	ms
T6	200	-	-	ms
T7	10	-	100	ms
T8	10	-	-	ms
T9	10	-	-	ms
T10	20	-	50	ms

Note (1) The supply voltage of the external system for the module input should be the same as the definition of Vcc.

Note (2) When the backlight turns on before the LCD operation of the LCD turns off, the display may momentarily become abnormal screen.

- Note (3) In case of Vcc = off level, please keep the level of input signals on the low or keep a high impedance.
- Note (4) T4 should be measured after the module has been fully discharged between power off and on period.
- Note (5) Interface signal shall not be kept at high impedance when the power is on.
- Note (6) There might be slight electronic noise when LCD is turned off(even backlight unit is also off).To avoid this symptom, we suggest "Vcc falling timing" o follow"T7 spec".

4.3 LVDS INPUT SIGNAL SPECIFICATIONS

4.3.1 LVDS DATA MAPPING TABLE

LVDS Channel O0	LVDS output	D7	D6	D4	D3	D2	D1	D0
	Data order	OG0	OR5	OR4	OR3	OR2	OR1	OR0
LVDS Channel O1	LVDS output	D18	D15	D14	D13	D12	D9	D8
	Data order	OB1	OB0	OG5	OG4	OG3	OG2	OG1
LVDS Channel O2	LVDS output	D26	D25	D24	D22	D21	D20	D19
	Data order	DE	NA	NA	OB5	OB4	OB3	OB2
LVDS Channel O3	LVDS output	D23	D17	D16	D11	D10	D5	D27
	Data order	NA	OB7	OB6	OG7	OG6	OR7	OR6
LVDS Channel E0	LVDS output	D7	D6	D4	D3	D2	D1	D0
	Data order	EG0	ER5	ER4	ER3	ER2	ER1	ER0
LVDS Channel E1	LVDS output	D18	D15	D14	D13	D12	D9	D8
	Data order	EB1	EB0	EG5	EG4	EG3	EG2	EG1
LVDS Channel E2	LVDS output	D26	D25	D24	D22	D21	D20	D19
	Data order	DE	NA	NA	EB5	EB4	EB3	EB2
LVDS Channel E3	LVDS output	D23	D17	D16	D11	D10	D5	D27
	Data order	NA	EB7	EB6	EG7	EG6	ER7	ER6

4.3.2 COLOR DATA INPUT ASSIGNMENT

The brightness of each primary color (red, green and blue) is based on the 8-bit gray scale data input for the color. The higher the binary the color. The table below provides the assignment of color versus data input.

Color		Data Signal																							
		Red								Green								Blue							
		R7	R6	R5	R4	R3	R2	R1	R0	G7	G6	G5	G4	G3	G2	G1	G0	B7	B6	B5	B4	B3	B2	B1	B0
Basic Colors	Black	0	0	0	0	0	0	0	0	0	0	0	0	0	0	0	0	0	0	0	0	0	0	0	0
	Red	1	1	1	1	1	1	1	1	0	0	0	0	0	0	0	0	0	0	0	0	0	0	0	0
	Green	0	0	0	0	0	0	0	0	1	1	1	1	1	1	1	1	0	0	0	0	0	0	0	0
	Blue	0	0	0	0	0	0	0	0	0	0	0	0	0	0	0	0	1	1	1	1	1	1	1	1
	Cyan	0	0	0	0	0	0	0	0	1	1	1	1	1	1	1	1	1	1	1	1	1	1	1	1
	Magenta	1	1	1	1	1	1	1	1	0	0	0	0	0	0	0	0	1	1	1	1	1	1	1	1
	Yellow	1	1	1	1	1	1	1	1	1	1	1	1	1	1	1	1	0	0	0	0	0	0	0	0
	White	1	1	1	1	1	1	1	1	1	1	1	1	1	1	1	1	1	1	1	1	1	1	1	1
Gray Scale Of Red	Red(0) / Dark	0	0	0	0	0	0	0	0	0	0	0	0	0	0	0	0	0	0	0	0	0	0	0	0
	Red(1)	0	0	0	0	0	0	0	1	0	0	0	0	0	0	0	0	0	0	0	0	0	0	0	0
	Red(2)	0	0	0	0	0	0	1	0	0	0	0	0	0	0	0	0	0	0	0	0	0	0	0	0
	:	:	:	:	:	:	:	:	:	:	:	:	:	:	:	:	:	:	:	:	:	:	:	:	:
	:	:	:	:	:	:	:	:	:	:	:	:	:	:	:	:	:	:	:	:	:	:	:	:	:
	Red(253)	1	1	1	1	1	1	0	1	0	0	0	0	0	0	0	0	0	0	0	0	0	0	0	0
	Red(254)	1	1	1	1	1	1	1	0	0	0	0	0	0	0	0	0	0	0	0	0	0	0	0	0
Red(255)	1	1	1	1	1	1	1	1	0	0	0	0	0	0	0	0	0	0	0	0	0	0	0	0	
Gray Scale Of Green	Green(0)/Dark	0	0	0	0	0	0	0	0	0	0	0	0	0	0	0	0	0	0	0	0	0	0	0	0
	Green(1)	0	0	0	0	0	0	0	0	0	0	0	0	0	0	1	0	0	0	0	0	0	0	0	0
	Green(2)	0	0	0	0	0	0	0	0	0	0	0	0	0	0	1	0	0	0	0	0	0	0	0	0
	:	:	:	:	:	:	:	:	:	:	:	:	:	:	:	:	:	:	:	:	:	:	:	:	:
	:	:	:	:	:	:	:	:	:	:	:	:	:	:	:	:	:	:	:	:	:	:	:	:	:
	Green(253)	0	0	0	0	0	0	0	1	1	1	1	1	1	1	0	1	0	0	0	0	0	0	0	0
	Green(254)	0	0	0	0	0	0	0	1	1	1	1	1	1	1	1	0	0	0	0	0	0	0	0	0
Green(255)	0	0	0	0	0	0	0	1	1	1	1	1	1	1	1	1	0	0	0	0	0	0	0	0	
Gray Scale Of Blue	Blue(0) / Dark	0	0	0	0	0	0	0	0	0	0	0	0	0	0	0	0	0	0	0	0	0	0	0	0
	Blue(1)	0	0	0	0	0	0	0	0	0	0	0	0	0	0	0	0	0	0	0	0	0	0	0	1
	Blue(2)	0	0	0	0	0	0	0	0	0	0	0	0	0	0	0	0	0	0	0	0	0	0	1	0
	:	:	:	:	:	:	:	:	:	:	:	:	:	:	:	:	:	:	:	:	:	:	:	:	:
	:	:	:	:	:	:	:	:	:	:	:	:	:	:	:	:	:	:	:	:	:	:	:	:	:
	Blue(253)	0	0	0	0	0	0	0	0	0	0	0	0	0	0	0	1	1	1	1	1	1	1	0	1
	Blue(254)	0	0	0	0	0	0	0	0	0	0	0	0	0	0	0	1	1	1	1	1	1	1	1	0
Blue(255)	0	0	0	0	0	0	0	0	0	0	0	0	0	0	0	1	1	1	1	1	1	1	1	1	

Note (1) 0: Low Level Voltage, 1: High Level Voltage

5.0 Optical Specifications

The optical characteristics are measured under stable conditions as following notes

Item	Conditions		Min.	Typ.	Max.	Unit	Note
Viewing Angle (CR>10)	Horizontal	θ_{x-}	80	85	-	degree	Note (1)(5)
		θ_{x+}	80	85	-		
	Vertical	θ_{y-}	80	85	-		
		θ_{y+}	80	85	-		
Contrast Ratio	Center		600	800	-	-	Note (2)(5)
Response Time	Rising + Falling		-	25	35	ms	Note (3)
Color Chromaticity (CIE1931)	Red	x	Typ. -0.05	0.652	Typ. +0.05	-	Note (1)(5)
	Red	y		0.338		-	
	Green	x		0.333		-	
	Green	y		0.613		-	
	Blue	x		0.150		-	
	Blue	y		0.050		-	
	White	x		0.313		-	
	White	y		0.329		-	
White Luminance	Center		300	380	-	cd/m ²	Note (4)(5)
Luminance Uniformity	9Points		70	-	-	%	Note (5)(6)

Note (1) Definition of Viewing Angle (θ_x , θ_y):

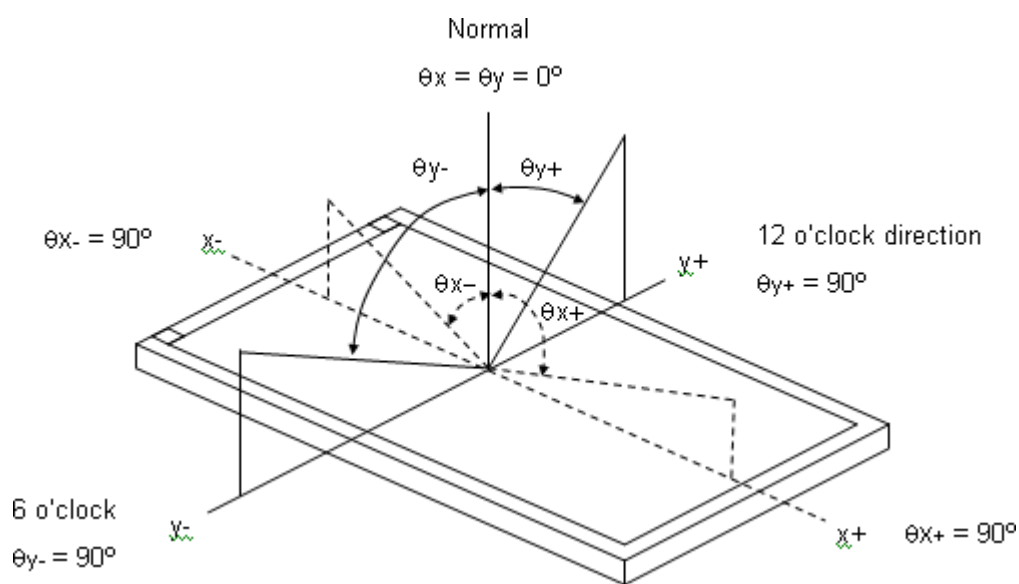

Note (2) Definition of Contrast Ratio (CR):

The contrast ratio can be calculated by the following expression. Contrast Ratio (CR) = L_{255} / L_0

L_{255} : Luminance of gray level 255 L_0 : Luminance of gray level 0

CR = CR (5)

CR (X) is corresponding to the Contrast Ratio of the point X at Figure in Note (6).

Note (3) Definition of Response Time (T_R , T_F):

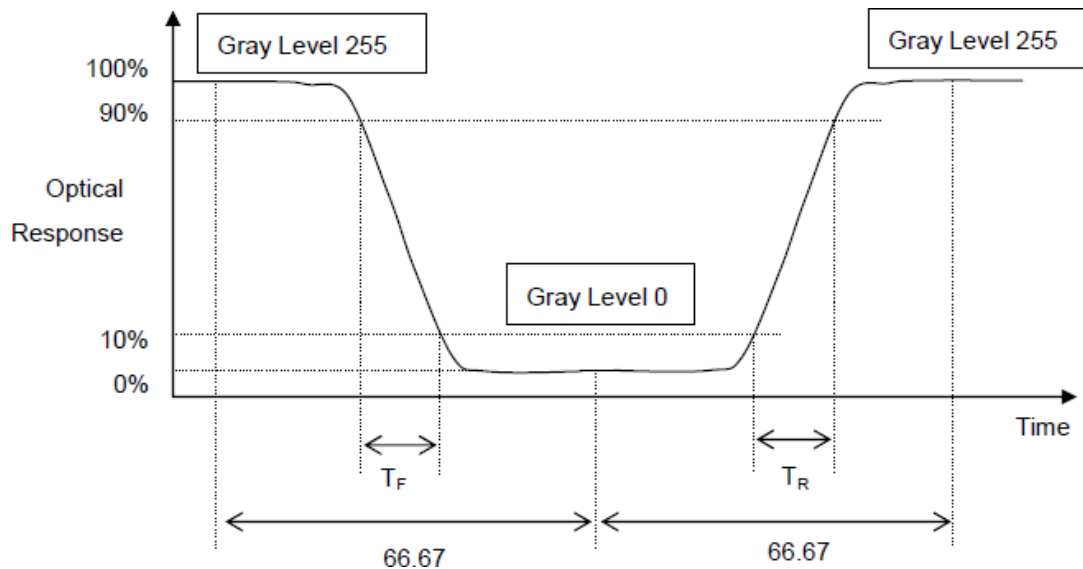

Note (4) Definition of Luminance of White (L_C):

Measure the luminance of gray level 255 at center point $L_C = L$ (5)

$L(x)$ is corresponding to the luminance of the point X at Figure in Note (6).

Note (5) Measurement Setup:

The LCD module should be stabilized at given temperature for 30 minutes to avoid abrupt temperature change during measuring. In order to stabilize the luminance, the measurement should be executed after lighting Backlight for 30 minutes in a windless room.

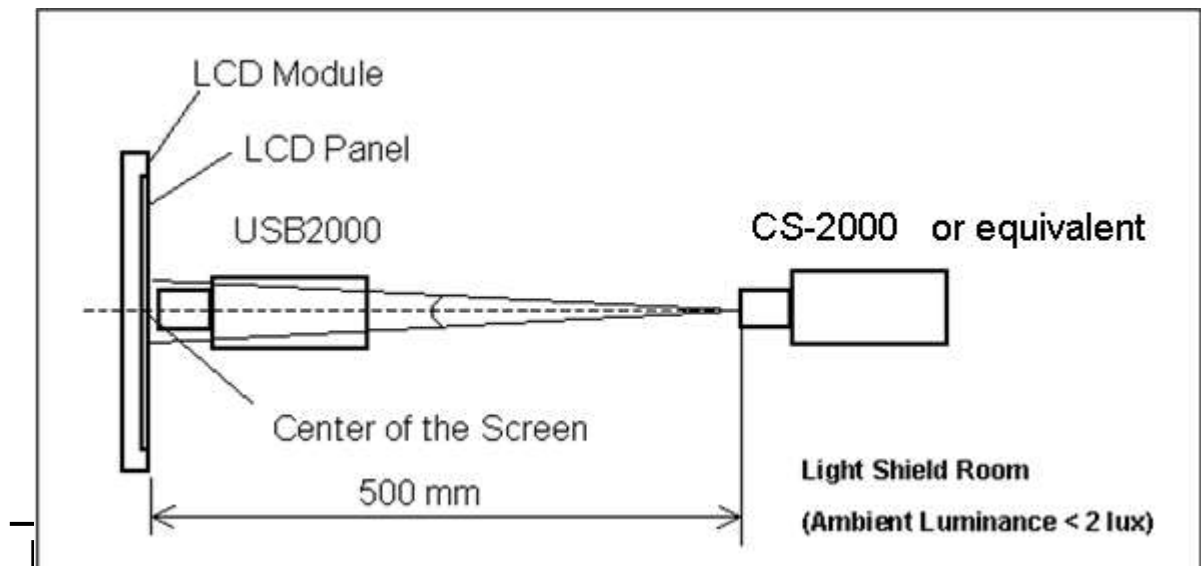

Note (6) Definition of White Variation

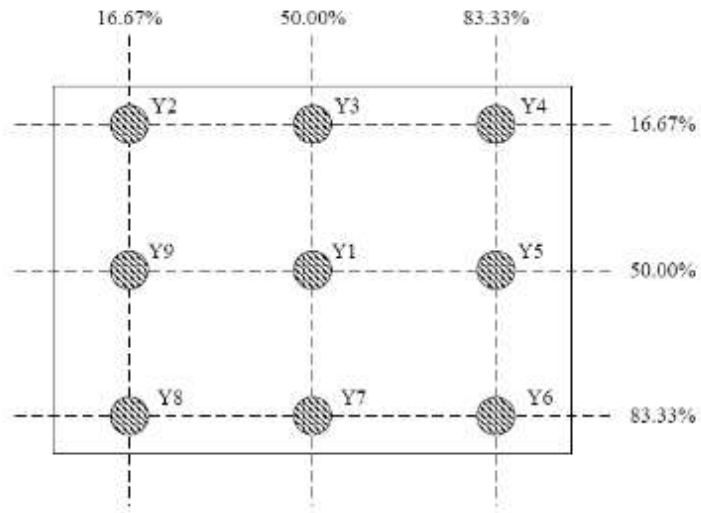

$$\text{Luminance uniformity} = \frac{\text{(Min Luminance of 9 points)}}{\text{(Max Luminance of 9 points)}} \times 100\%$$

6. Interface Connections

Pin	Name	Description
1	LED_Vcc	+12V Vi power supply
2	LED_Vcc	+12V Vi power supply
3	LED_Vcc	+12V Vi power supply
4	LED_Vcc	+12V Vi power supply
5	GND	Ground
6	GND	Ground
7	GND	Ground
8	GND	Ground
9	LED_EN	Enable pin
10	LED_PWM	Backlight Adjust
11	LCD_VCC	LCD logic and driver power 3.3V
12	LCD_VCC	LCD logic and driver power 3.3V
13	LCD_VCC	LCD logic and driver power 3.3V
14	NC	Not connection, this pin should be open
15	NC	Not connection, this pin should be open
16	NC	Not connection, this pin should be open
17	LCD GND	LCD logic and driver ground
18	RXO0-	Negative LVDS differential data input. Channel O0 (odd)
19	RXO0+	Positive LVDS differential data input. Channel O0 (odd)
20	RXO1-	Negative LVDS differential data input. Channel O1 (odd)
21	RXO1+	Positive LVDS differential data input. Channel O1 (odd)
22	RXO2-	Negative LVDS differential data input. Channel O2 (odd)
23	RXO2+	Positive LVDS differential data input. Channel O2 (odd)
24	LCD GND	LCD logic and driver ground
25	RXOC-	Negative LVDS differential clock input. (odd)
26	RXOC+	Positive LVDS differential clock input. (odd)
27	LCD GND	LCD logic and driver ground
28	RXO3-	Negative LVDS differential data input. Channel O3(odd)
29	RXO3+	Positive LVDS differential data input. Channel O3 (odd)
30	RXE0-	Negative LVDS differential data input. Channel E0 (even)
31	RXE0+	Positive LVDS differential data input. Channel E0 (even)
32	RXE1-	Negative LVDS differential data input. Channel E1 (even)
33	RXE1+	Positive LVDS differential data input. Channel E1 (even)
34	LCD GND	LCD logic and driver ground
35	RXE2-	Negative LVDS differential data input. Channel E2 (even)
36	RXE2+	Positive LVDS differential data input. Channel E2 (even)
37	RXEC-	Negative LVDS differential clock input. (even)
38	RXEC+	Positive LVDS differential clock input. (even)
39	RXE3-	Negative LVDS differential data input. Channel E3 (even)
40	RXE3+	Positive LVDS differential data input. Channel E3 (even)

7. LED Driving Conditions

Parameter	Symbol	Value			Unit	Note	
		Min.	Typ.	Max.			
Converter Power Supply Voltage	LED_Vin	10.8	12.0	13.2	V		
Converter Power Supply Current	li	0.8	1.0	1.2	A	@LED_Vin= 12V Duty=100%	
Converter Input Rush Current	lirsh			3	A	@LED_Vin rising = 1mS	
Power Consumption	P _{LED}		12		W	@ LED_Vin = 12V Duty=100%	
EN Control Level	Backlight on	LED_EN	2.0	5	5.5	V	
	Backlight off		0	0	0.15		
PWM Control Level	PWM High Level	LED_PWM	2.0	3.3	5.0	V	
	PWM Low Level		0	0	0.15		
PWM Control Duty Ratio			10	--	100	%	
PWM Control Frequency		f _{PWM}	190	200	20k	Hz	
LED Life Time		L _L	50,000			Hrs	(2)

Note (1) LED light bar input voltage and current are measured by utilizing a true RMS multimeter as shown below:

Note (2) The lifetime of LED is estimated data and defined as the time when it continues to operate under the conditions at $T_a = 25 \pm 2^\circ\text{C}$ and Duty 100% until the brightness becomes $\leq 50\%$ of its original value. Operating LED under high temperature environment will reduce life time and lead to color shift.

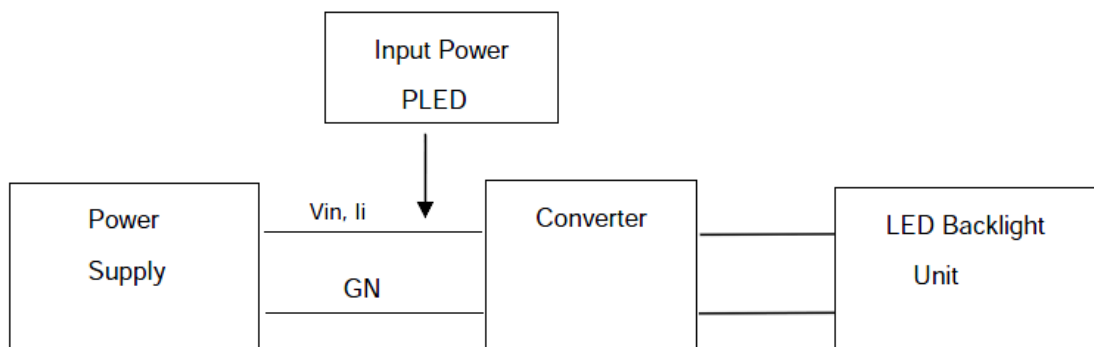

1.0 Touch Panel Electrical Specification

8.1 Electrical Characteristics

Item	Specification
Type	Projective Capacitive Touch Panel
Activation	Multi-fingers or Single-finger
X/Y Position Reporting	Absolute Position
Touch Force	No contact pressure required
Calibration	No need for calibration
Report Rate	Approx. 200 points/sec
Control IC	ILI2510

Item	Symbol	Min.	Typ.	Max.	Unit
Touch panel power supply	VIN	4.75	5	5.25	V
Touch panel power supply current at Normal operation mode	IVIN	--	45(Reference)	--	mA
Touch panel power supply current at USB suspend mode	IVIN	--	TBD	--	uA

8.2 Interface

Pin No.	Symbol	Function
1	GND	GND
2	DA-	USB Data-
3	DA+	USB Data+
4	VIN	USB POWER 5V
5	NA	No connection
6	NA	No connection

9. Reliability Test

The reliability test items and its conditions are shown below.

Test Item	Test Conditions	Note
High Temperature Operation	70±3°C , t=240 hrs	
Low Temperature Operation	-20±3°C , t=240 hrs	
High Temperature Storage	80±3°C , t=240 hrs	1,2
Low Temperature Storage	-30±3°C , t=240 hrs	1,2
Storage at High Temperature and Humidity	60°C, 90% RH , 240 hrs	1,2
Thermal Shock Test	-30°C (30min) ~ 85°C (30min) , 100 cycles	1,2
Shock (Non-Operating)	50G, 11ms, half sine wave, 1 time for ± X, ± Y, ± Z.	
Vibration (Non-Operating)	1.5G, 10 ~ 300 Hz, 10min/cycle, 3 cycles each X, Y, Z	

Note (1) Condensation of water is not permitted on the module.

Note (2) The module should be inspected after 1 hour storage in normal conditions (15-35°C, 45-65%RH).

Note (3) The module shouldn't be tested more than one condition, and all the test conditions are independent.

Note (4) All the reliability tests should be done without protective film on the module.

10 . GENERAL PRECAUTION

10.1 Use Restriction

This product is not authorized for use in life supporting systems, aircraft navigation control systems, military systems and any other application where performance failure could be life-threatening or otherwise catastrophic.

10.2 Disassembling or Modification

Do not disassemble or modify the module. It may damage sensitive parts inside LCD module, and may cause scratches or dust on the display. AMPIRE does not warrant the module, if customers disassemble or modify the module.

10.3 Breakage of LCD Panel

- (1) If LCD panel is broken and liquid crystal spills out, do not ingest or inhale liquid crystal, and do not contact liquid crystal with skin.
- (2) If liquid crystal contacts mouth or eyes, rinse out with water immediately.
- (3) If liquid crystal contacts skin or cloths, wash it off immediately with alcohol and rinse thoroughly with water.
- (4) Handle carefully with chips of glass that may cause injury, when the glass is broken.

10.4 Electric Shock

- (1) Disconnect power supply before handling LCD module.
- (2) Do not pull or fold the LED cable.
- (3) Do not touch the parts inside LCD modules and the fluorescent LED's connector or cables in order to prevent electric shock.

10.5 Absolute Maximum Ratings and Power Protection Circuit

- (1) Do not exceed the absolute maximum rating values, such as the supply voltage variation, input voltage variation, variation in parts' parameters, environmental temperature, etc., otherwise LCD module may be damaged.
- (2) Please do not leave LCD module in the environment of high humidity and high temperature for a long time.
- (3) It's recommended to employ protection circuit for power supply.

10.6 Operation

- (1) Do not touch, push or rub the polarizer with anything harder than HB pencil lead.
- (2) Use fingerstalls of soft gloves in order to keep clean display quality, when persons handle the LCD module for incoming inspection or assembly.
- (3) When the surface is dusty, please wipe gently with absorbent cotton or other soft material.
- (4) Wipe off saliva or water drops as soon as possible. If saliva or water drops contact with polarizer for a long time, they may cause deformation or color fading.
- (5) When cleaning the adhesives, please use absorbent cotton wetted with a little petroleum benzene or other adequate solvent.

10.7 Mechanism

Please mount LCD module by using mounting holes arranged in four corners tightly.

10.8 Static Electricity

- (1) Protection film must remove very slowly from the surface of LCD module to prevent from electrostatic occurrence.
- (2) Because LCD modules use CMOS-IC on circuit board and TFT-LCD panel, it is very weak to electrostatic discharge. Please be careful with electrostatic discharge. Persons who handle the module should be grounded through adequate methods.

10.9 Strong Light Exposure

The module shall not be exposed under strong light such as direct sunlight. Otherwise, display characteristics may be changed.

10.10 Disposal

When disposing LCD module, obey the local environmental regulations.

9.11 Others

Do not keep the LCD at the same display pattern continually. The residual image will happen and it will damage the LCD. Please use screen saver.

11.0 Outline Dimension

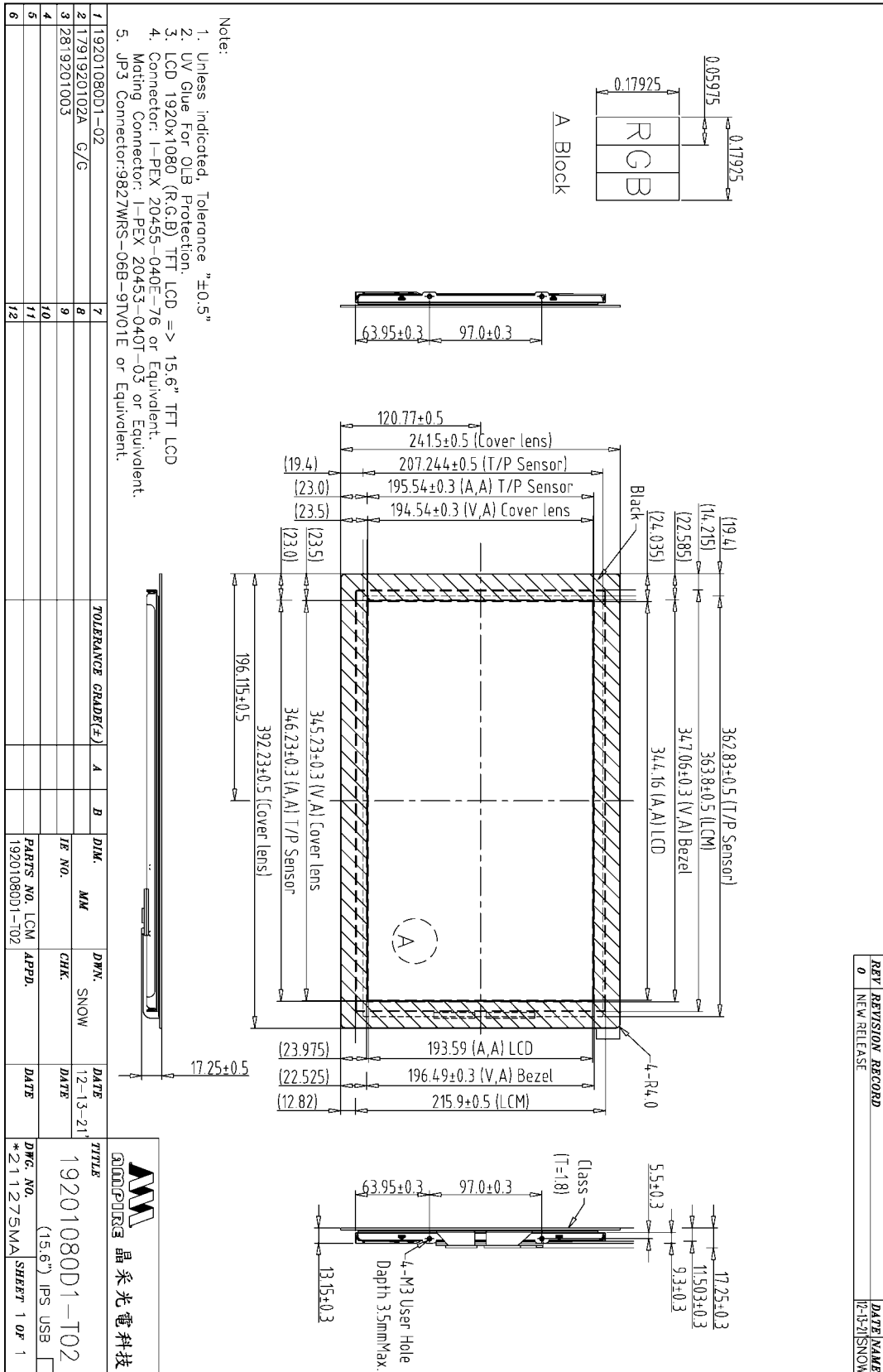

REV	REVISION RECORD	DATE	NAME
0	NEW RELEASE	12-13-21	SNOW

USB Interface:

1	GND
2	DA-
3	DA+
4	VIN
5	NA
6	NA

1	LED_VCC	21	RX01+
2	LED_VCC	22	RX02-
3	LED_VCC	23	RX02+
4	LED_VCC	24	LCD_GND
5	GND	25	RX0C-
6	GND	26	RX0C+
7	GND	27	LCD_GND
8	GND	28	RX03-
9	LED_EN	29	RX03+
10	LED_PWM	30	RX0D-
11	LCD_VCC	31	RX0D+
12	LCD_VCC	32	RX1E-
13	LCD_VCC	33	RX1E+
14	NC	34	LCD_GND
15	NC	35	RX1E2-
16	NC	36	RX1E2+
17	LCD_GND	37	RX1E3-
18	RX00-	38	RX1E3+
19	RX00+	39	RX1E3-
20	RX01-	40	RX1E3+

Note:

- Unless indicated, Tolerance "±0.5"
- UV Glue For OLB Protection.
- LCD 1920x1080 (R.G.B) TFT LCD => 15.6" TFT LCD
- Connector: I-PEX 20455-040E-76 or Equivalent.
Mating Connector: I-PEX 20453-040T-03 or Equivalent.
- JP3 Connector: 9827WRS-06B-9TV01E or Equivalent.

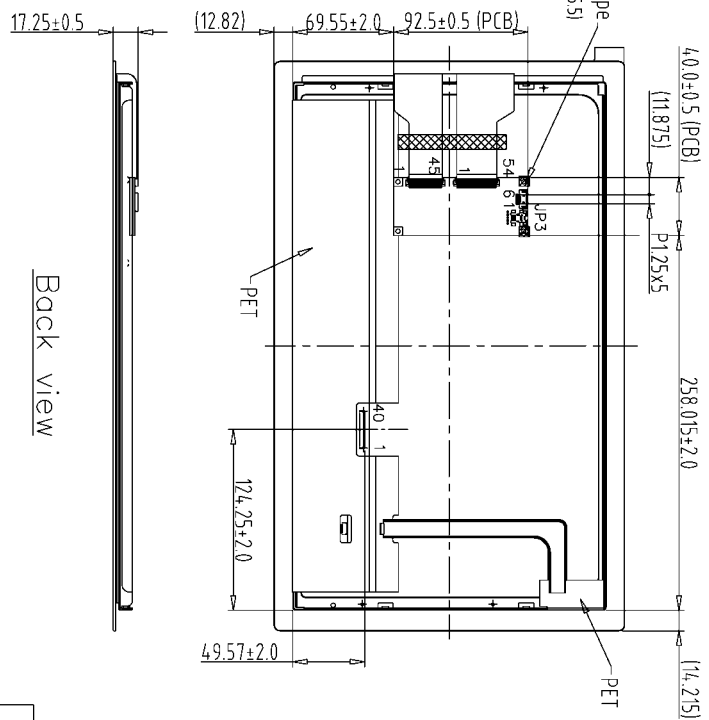
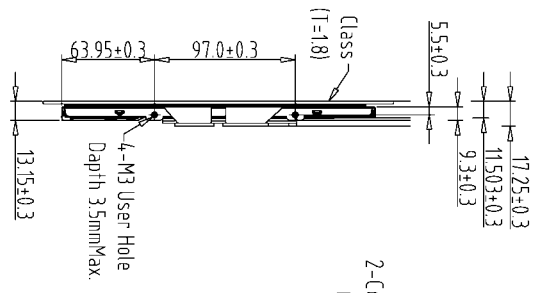

Back view

NO.	REV	DESCRIPTION	DATE	NAME
1	19201080D1-02			
2	1791920102A	G/C		
3	2819201003			
4				
5				
6				

NO.	REV	DESCRIPTION	DATE	NAME
7		TOLEANCE GRADIENT		
8				
9				
10				
11				
12				

DIM.	MM	DWN.	SNOW	DATE
IE NO.		CHK.		DATE
PARTS NO. LCM-1	19201080D1-102	APPD.		DATE

MM	晶采光電科技
GROUP	
TITLE	19201080D1-T02
DWG. NO.	(15.6") IPS USB
	*211276WA SHEET 1 OF 1